



**PRESSURE SWITCHES
PRESSURE DIFFERENCE SWITCHES
VACUUM SWITCHES**
From 1.5 mbar to 600 bar

MZ Pressure Switch

INSTALLATION AND OPERATING INSTRUCTIONS



Kaustubha Udyog (Orion Instruments)

S. No. 36/1/1, Sinhgad Road, Vadgaon Khurd, Pune 411 041 INDIA
Tel.: +91-(0) 20-24393877
Telefax : +91-(0) 20-24393577 / 25460486
Email : ku.pressure@gmail.com / info@orion-instruments.io

Certificate No.: FM72815



Website : www.orion-instruments.io

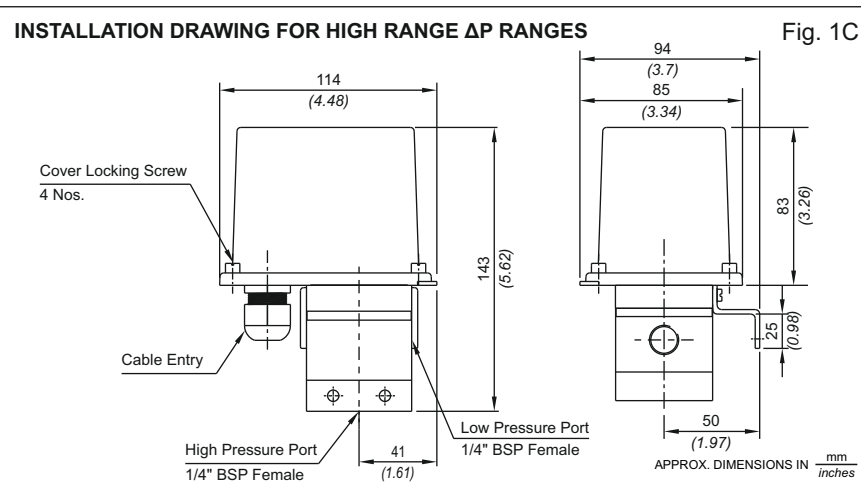
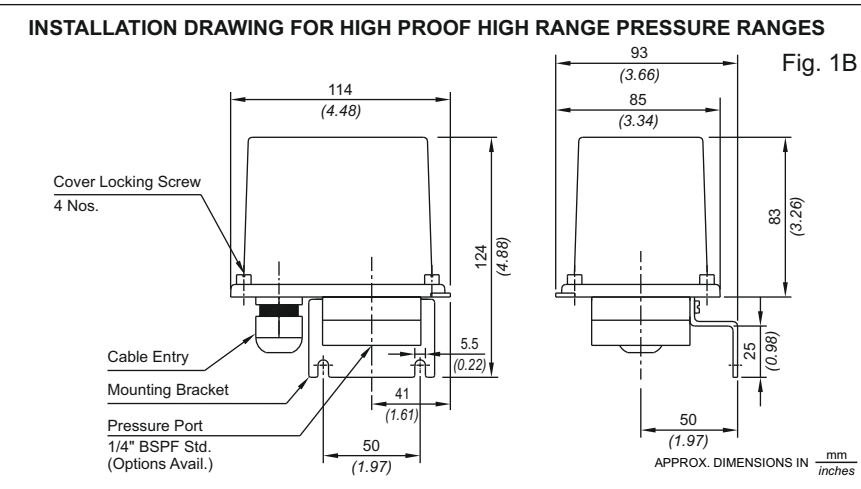
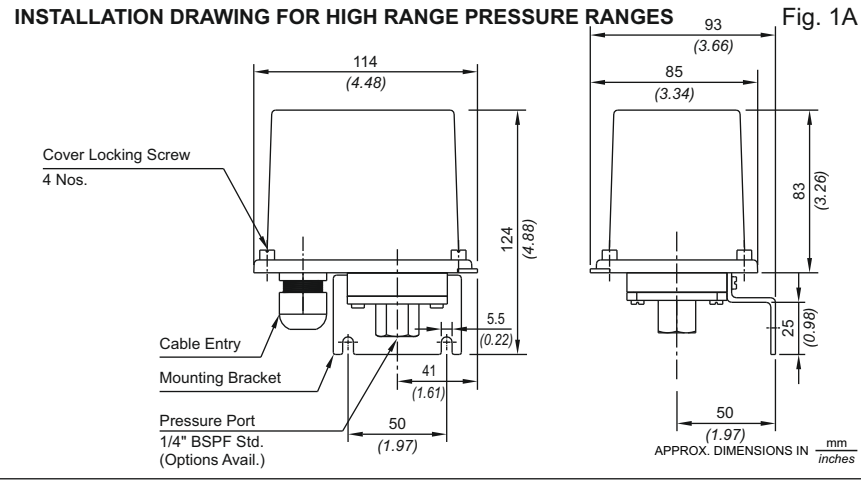

Construction

The pressure switch is housed in a tough polycarbonate cover, fitted on a stainless steel base, retained by SS screws. The enclosure conforms to IP66 protection factor. A calibrated scale, as also the working of the switch is visible through the cover. The pressure capsule, at the bottom of the switch, comprises a pressure housing (either of aluminium, or SS316), a disc, nylon reinforced rubber / metal diaphragm and a plunger. For hydraulic ranges, a piston and Oring seal assembly is used. The electrical changeover is through a snapaction microswitch. 2 SPDT switching can be provided as an option. Other options like hermetically sealed microswitches etc, can be provided on checking feasibility, as per the order. The electrical wiring terminates at a terminal strip having screwed ends. The cable gland provided is M20 X 1.5 standard.

By using appropriate capsules and wetted parts, MZ series pressure switches can be used for thousands of applications.

Principle of Operation

The pressure in the pressure capsule is converted into force by means of a reinforced rubber / metal diaphragm and a calibrated piston, which is balanced by a compression spring from above. When the force generated by the pressure in the pressure capsule exceeds/falls beyond the balancing spring force, an electrical element is actuated through a bell crank lever mechanism for accurate switching.



Please use the pressure switch well within the pressure / vacuum / pressure difference as also the electrical parameters

Mounting

The high pressure range pressure switches can be mounted in any direction.

- 1) Please refer figure for the appropriate switch being used.
 - a) Pressure / Vacuum switches can be mounted directly in case the mounting is rigid.
 - b) For panel mounting, fix the bracket provided to the pressure / vacuum switch. Please use M5 bolts of appropriate length through the mounting holes. If the equipment is subject to vibration, please use rubber washers / pads between the panel and the switch.

2. Connect the pressure tubing to the pressure / vacuum port (s). The pressure port size is generally 1/4" B.S.P. female, unless specially ordered otherwise. Other sizes can be obtained via adaptors.

Electrical Connections

Pressure switches will generally have only one SPDT microswitch.

Pressure switches with two SPDT microswitches can also be provided. For 2 SPDT microswitches, the scale will correspond to one microswitch. The setpoint of the other microswitch will vary and the on-off differential of the other microswitch will depend on the stage difference between the two setpoints.

Please use electrical loads well within the limits specified for the microswitch.

Fig. 2

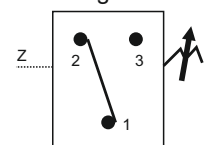

Wiring

Please refer figure 3 .

- a) Remove the top cover.
- b) Pass the cable through the cable gland (usually provided with switch) and connect the wiring as per the wiring diagram.

The wiring code is as per the details given below.

terminal 1 : (C) Common
terminal 2 : (NC) Normally Closed
terminal 3 : (NO) Normally Open



Please disconnect supply before wiring the switch, or removing the wiring. The cover should not be removed, if the supply is on.

Set Point Adjustment

Ensure the supply is off, before setting the switch. Status of contacts can be checked with a multimeter / continuity tester.

A) For switches with fixed differentials :

Refer figure 3

- 1) Remove the cover. The retaining screws are engaged in the cover, just loosening them should unfasten the cover.
- 2) Adjust the desired setpoint on the scale.
- 3) Apply the desired cutin (lower) / cutout (higher) pressure to the pressure switch.
- 4) Some minor adjustment will be required to achieve the exact cutin (lower) / cutout (higher) point, which can be checked with the help of a proper pressure / vacuum measurement device.
- 5) Replace the cover and tighten the screws.

B) For adjustable differential models

Please refer Figure 3

- 1) Decide the cut-in (lower) pressure P1 & the cut-out (upper) pressure P2. The differential will be $(P2 - P1)$.
- 2) Remove the cover. The retaining screws are engaged in the cover, just loosening them should unfasten the cover
- 3) Set the cut-in point on the main-scale with the help of the set-screw.
- 4) Turn the differential screw to the extreme positive end.
- 5) Apply the desired cutout (higher) pressure to the pressure

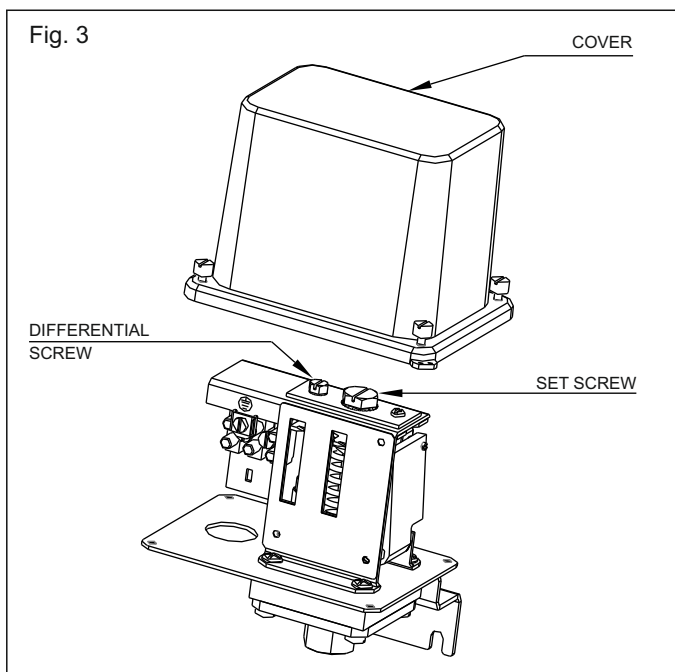

switch

- 6) Decrease the differential pressure setting by turning the differential screw till contacts changeover.
- 7) Some minor adjustment will be required to achieve the exact cutin (lower) / cutout (higher) point, which can be checked with the help of a proper pressure measurement device.
- 8) Replace the cover and tighten the screws.

Operating Temperatures:

The operating condition temperature restrictions for the Flameproof switch FC are as follows:

Ambient : -5 °C to +60 °C

Operational (all models) : -5 °C to +80 °C (150 °C for metallic diaphragms)

Note : Switches with temperature ranges beyond the ones specified above can be supplied on request.

storage : -5 °C to +60 °C

Trouble Shooting Tips

Generally no problems are observed if the pressure switch selection, wiring and the setpoint is proper. For a pressure switch selection procedure, please consult our sales office.

For properly selected pressure switches, if following symptoms are observed, the likely causes and remedies are as stated below.

Symptom 1: Switch does not operate

- 1) Wiring may not be correct. Check electrical connections to the pressure switch, if they are as per the wiring diagram.
 - 2) Pressure does not reach the pressure port.
 - a) Check if the entry to the pressure capsule is not blocked by frozen process or scales or impurities in the process.
 - i) If this is the case, try freeing the blocked path by a blunt tool in case of scales or impurities.
 - ii) For frozen process, it is advisable to use chemical seals.
- DO NOT OPEN THE PRESSURE CAPSULE IN ANY EVENT.**
- i) For adjustable differential models turn the differential screw to the extreme negative end.



If the cause is none of the above mentioned probabilities, proceed as per the following steps.

- b) Check the system pressure & set point of pressure switch. For use of pressure switch for falling setpoints, system pressure has to be greater than cutin point. For use of pressure switch for rising setpoints, the system pressure may not be reaching / exceeding the cutout point.

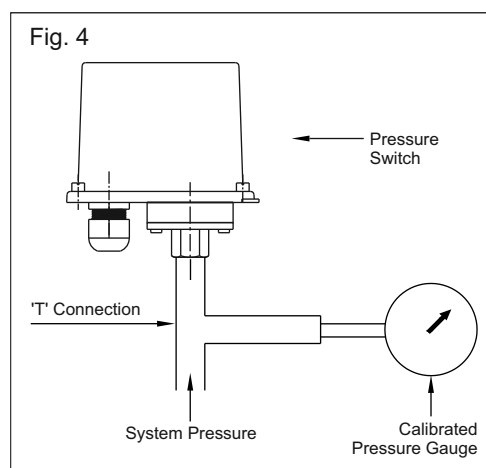

- ii) Use 'T' connection & connect calibrated pressure gauge to the 'T' connection as shown in the figure 4.
- iii) Adjust the setpoint such that the system pressure is greater than the cut-out point of the pressure switch.
- iv) If the switch still does not operate, remove the pressure switch physically from the system. There should be continuity between terminals 1 & 2. If no continuity is observed, the pressure switch should be returned to the factory.

Symptom 2: Short Wiring

Isolate the switch electrically. Check the continuity between terminals and the screws fitted to the body. If no continuity is observed in between any of the terminals and screws fitted to the body, check the short connection elsewhere in the circuit. If continuity is observed, the wires of the pressure switch have internally touched the body, and the switch should be returned to the factory.

Symptom 3: Leakage

In case leakage is observed, the pressure switch has to be returned to the factory without opening the pressure capsule. Check for the following likely causes and use a new switch taking proper precautions.

- a) System pressure is greater than working pressure : Use an overrange protector or a switch with appropriate maximum working pressure.
- b) Incompatible wetted parts : The working medium may not be compatible with wetted parts, which damages the sealing of the process from working parts. Use a chemical seal for the pressure switch or use proper compatible wetted parts.
- c) Excessive process temperature : Process temperature may exceed maximum allowable temperature, which in turn damages the diaphragms. Use an impulse tubing of proper length for cooling the process temperature. There may be a pressure drop depending on length of the impulse tube used. Adjust the setpoint of the pressure switch accordingly.

Symptom 4: Chattering

- 1) Check the system pressure for surges. Chattering is observed where the system pressure is close to the cutin / cutout point and the surge pressure exceeds the on-off differential. Use a pressure switch with an adjustable differential or use surge dampers in your system.
- 2) If there is a relay in the circuit, check if the relay is properly plugged in. Chattering may be due to loose contacts. ■

